

VXS TEST EXTENDER

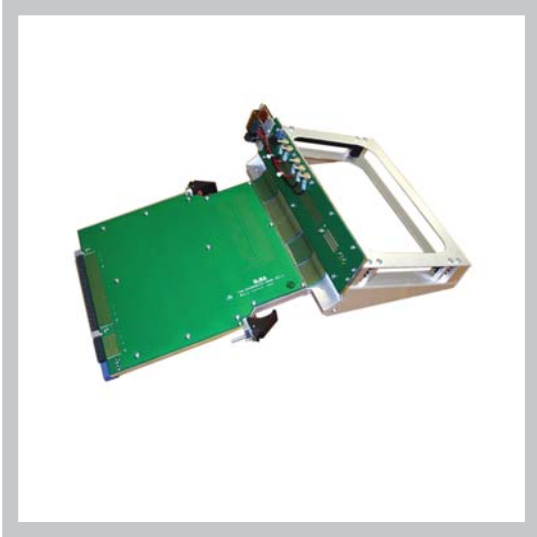

FEATURES

- Conforms to VITA 41.0 VXS backplane specifications
- Controlled impedance rigid-flex-rigid design
- Alignment keying headers provided for extender and plug-in card
- 100 Ohm differential pair routing
- J1 signals are single-ended signals and run point-to-point across the extender
- Mechanical frame supports 6U, 160mm plug-in card
- Frame has injector/ejector latches for plug-in card
- Signal rate: 3.125 Gb/sec
- +5V on/off switch
- Current monitor on +5V power
- Frame has injector/ejector latches to hold extender securely to chassis

BOARD SPECIFICATIONS

- 10-layer stripline design
- PCB UL listed 94-V0
- PCB .080" thick
- PCB Material: L24 Type GFN

MECHANICAL SPECIFICATIONS

- 6U height
- 240mm
- Multi-Gig RT-2 connectors

POWER SPECIFICATIONS

- Switch Extender: Max load of 12A for the +5VDC voltage
- Payload Extender: Max load of 12A for the +3.3VDC or +5VDC voltages

DESCRIPTION

Elma Bustronic used creative engineering to solve a major problem in developing the VXS Extender Board - the lack of a right angle receptacle for VXS in the marketplace. So, the company produced a rigid-flex-rigid PCB design to get around the problem. The solution entails a right angle pin connector that plugs into the backplane, connected to a flex circuit that wires to the straight receptacle to receive the plug-in board.

The VXS extender boards are designed to bring a circuit card completely out of a card cage or enclosure so that it can be tested or debugged. This provides access to both sides of the test board. There are test points for all of the differential pairs on the MultiGig fabric connector for the hub slots.

VXS Switched Serial VME is relatively new architecture that utilizes both legacy VME and serial differential pair signals. The VXS Extender boards come in a 10-layer stripline design for the rigid PCB and microstrip design for the flex circuit portion. Also featured is an ampmeter, which measures the current and has a digital indicator on the front panel showing the status.

Elma Bustronic also offers extender boards in VXI, VME, AdvancedTCA and CompactPCI architectures. Other system accessories include load boards, power interface boards, shelf managers, system/voltage monitors, and more.

VXS TEST EXTENDER

LINE DRAWING

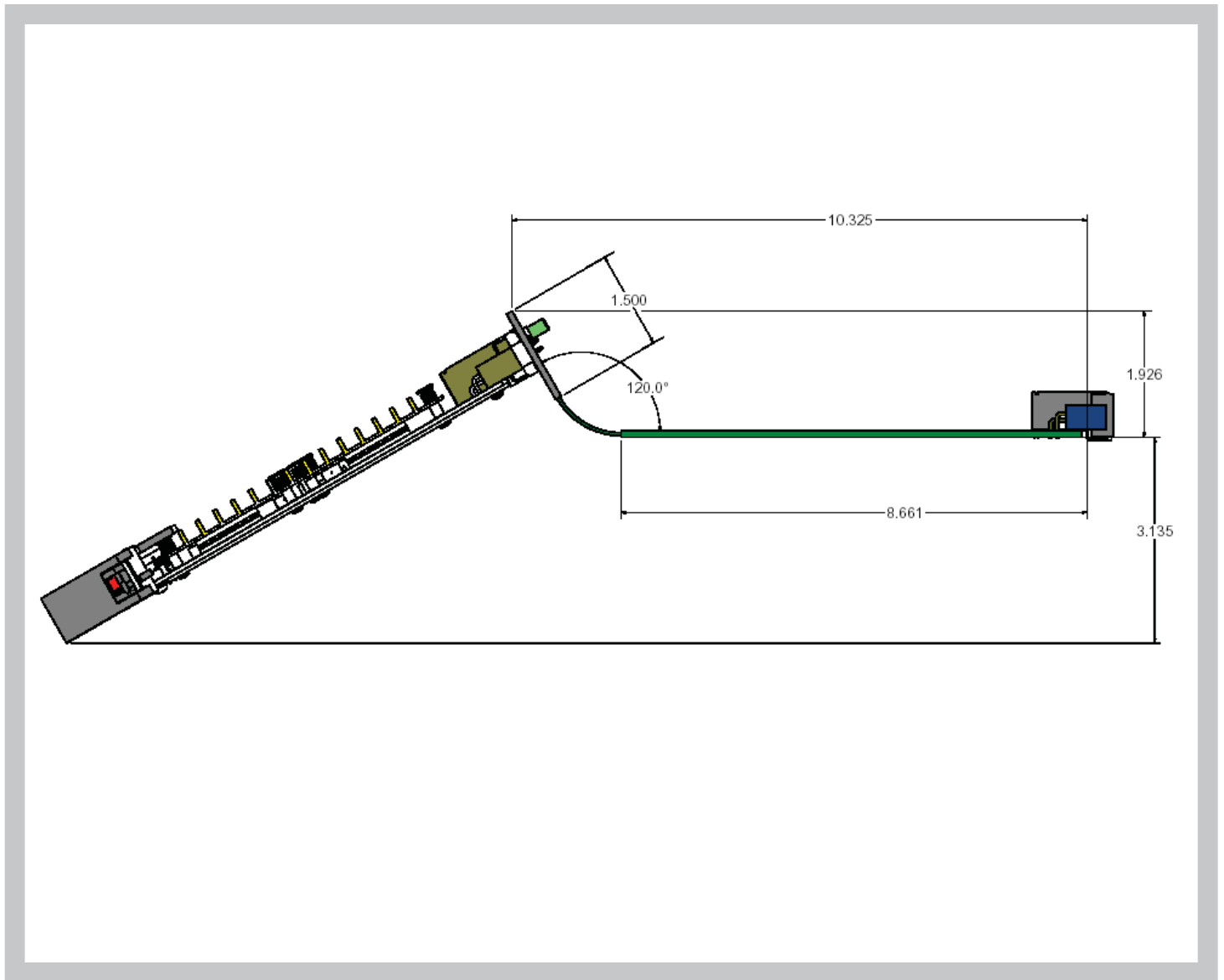

ORDER INFORMATION

Height	Length	Description	Part Number
6U	240mm	Switch (hub) slot extender	115EXT6024-0XXX
6U	240mm	Payload slot extender	118EXT6024-0XXX